



DAF – DETECT-A-FIRE Detection and Release Devices



FEATURES

- *Repeatable - resets itself, nothing to replace, testable*
- *Rugged - withstands shock and vibration*
- *Versatile - offers various temperature settings*
- *Durable - long lasting stainless steel shell*
- *Economical - wide spacing, reduces installation cost*
- *Factory set and the internal contact area is hermetically sealed in stainless steel*

APPLICATIONS

- *Protection of schools, hospitals, public facilities, factories, offices, libraries, transformer stations, tanks, etc.*
- *Paint spray booths*
- *Range hoods*
- *Marine engine rooms*

and many more !



DESCRIPTION:

DETECT-A-FIRE units are the "heart" of many Fire Protection Systems.

These highly reliable devices have been a standard of the industry for over 50 years. Many thousands of these units are now in use controlling the release of extinguishants such as clean agents, CO₂, water, or dry chemicals. In some systems the device is used as an ALARM device, to sense overheat or fire, and alert personnel. In other systems, it is used as a RELEASE device, to sense fire and actuate fire attack systems.

DETECT-A-FIRE units have met with wide acceptance because they are designed with RATE COMPENSATION. This provides a unique advantage over both fixed temperature and rate-of-rise types of detectors because only the DETECT-A-FIRE unit accurately senses the surrounding air temperature regardless of the fire growth rate. At precisely the predetermined danger point, the system is activated.

Fixed temperature detectors must be completely heated to alarm temperature and therefore a disastrous lag in time may occur with a fast rate fire. Rate-of-rise devices, on the other hand, are triggered by the rate of increase in ambient temperature and are subject to false alarms caused by harmless, transient thermal gradients such as the rush of warm air from process ovens.

VERTICAL DETECT-A-FIRE-UNITS

For Concealed and Exposed Wiring
(Hexagonal Head)

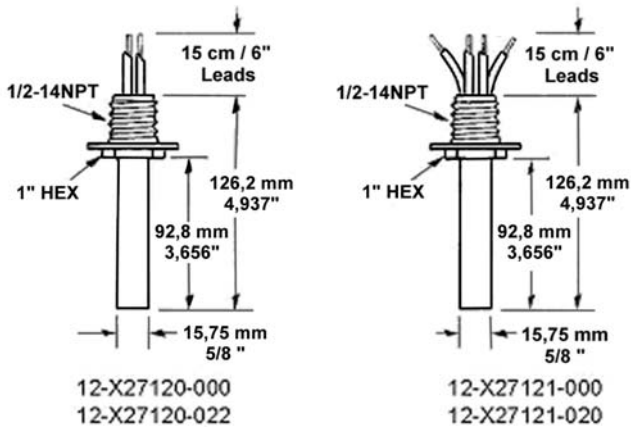

VERTICAL DETECT-A-FIRE-UNITS

For Concealed and Exposed Wiring
(Coupling Head)

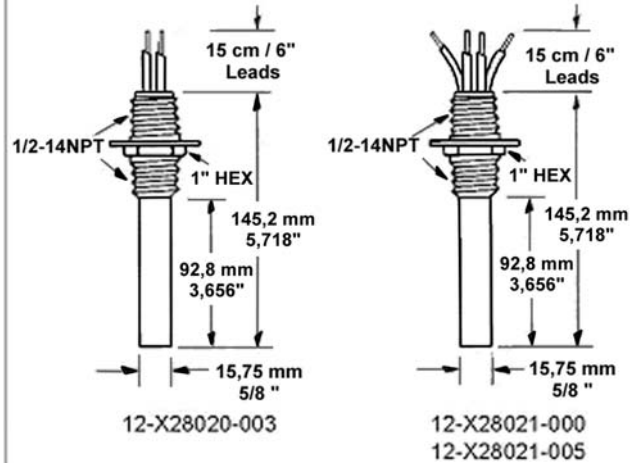

MODEL NUMBER	MOUNTING HEAD MATERIAL	SHELL MATERIAL	CONTACT OPERATION ON TEMP. RISE	ELECTR. RATING RESISTIVE ONLY	~WEIGHT PER UNIT
12-X27120-000	Brass +	Type 300 Stainless Steel	Opens (232°C/450° F Max)	5.0 Amps 125 VAC	141 g / 5 oz.
12-X27120-022	Type300 Stainless Steel			0.5 Amps 125 VDC	
12-X27121-000	Brass +		Closes	5.0 Amps 125 VAC	141 g / 5 oz.
12-X27121-020	Type300 Stainless Steel			0.5 Amps 125 VDC 2.0 Amps 24 VDC 1.0 Amps 48 VDC	
12X28020-003	Type300 Stainless Steel		Opens (232°C/450° F Max.)	5.0 Amps 125 VAC 0.5 Amps 125 VDC	141 g / 5 oz.
12-X28021-000	Brass +		Closes	5.0 Amps 125 VAC	141 g / 5 oz.
12-X28021-005	Type300 Stainless Steel			0.5 Amps 125 VDC 2.0 Amps 24 VDC 1.0 Amps 48 VDC	

Construction :

000 units have a Type300 stainless steel sensing shell and a brass mounting head, 002, 020, 003 and 005 units are all Type 300

Model	Temperature Setting										
	°C	60	71	88	107	135	165	187	232	315	385
	°F	140	160	190	225	275	325	360	450	600	725
x = Standardtype											
12-X27020-000		X		X							
12-X27020-001		X									
12-X27021-000		X		X							
12-X27021-001		X		X							
12-X27120-000			X	X	X		X				
12-X27121-000		X	X	X	X	X	X	X	X	X	X
12-X28021-005					X				X		

LICO Electronics GmbH, Klederinger Str. 31, A-2320 Kledering, Austria office@lico.at www.lico.at
LICO Hungaria Kft, Raba u.4, H-2030 Erd, Hungary office@lico.hu www.lico.hu

Tolerances ex works prior to shipment:

Typical System Wiring:

Setting °C	Toleranz °C	Setting °F	Toleranz °F	Color Code
60	.+3,8/-4,5	140	.+7/-8.	Black
71	.+4,0/-4,3.	160	.+7/-8.	Black
88	.+4,0/-4,3.	190	.+7/-8.	White
99	.+4,0/-4,3.	210	.+7/-8.	White
107	.+4,1/-4,3	225	.+7/-8.	White
135	.+5,5/-5,5.	275	.+10/-10	Blue
165	.+5,5/-5,5.	325	.+10/-10	Red
187	.+5,5/-5,5.	360	.+10/-10	Red
232	.+8,5/-8,1	450	.+15/-15	Green
260	.+8,3/-8,3	500	.+15/-15	Orange
315	.+11,6/-10,5	600	.+20/-20	Orange
385	.+13,9/-13,9	725	.+25/-25	Orange

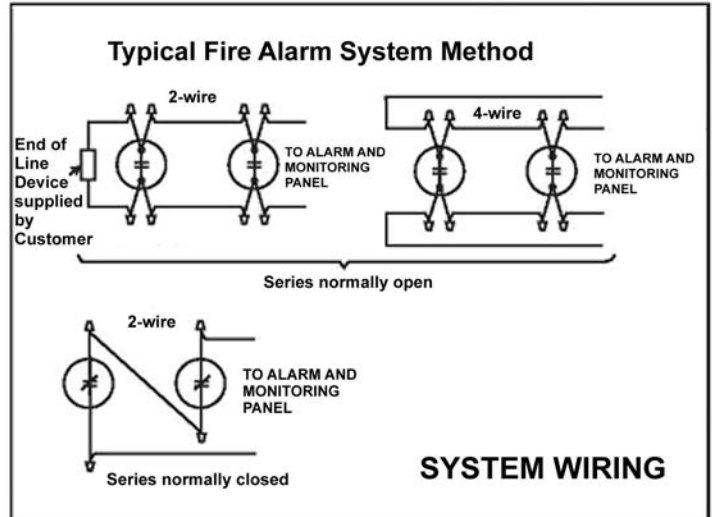

VERTICAL DETECT-A-FIRE-UNITS are UL, FM and Vds approved:

Vertical detectors are designed for use in both "ordinary" or "hazardous" locations. For "ordinary" use, they may be mounted to any appropriate tight metal junction box (preferred: solid Alu) with 7/8" diameter opening by using 1/2-14 NPT mounting nuts or into a 1/2-14NPT thread. The device may be wired in or out of conduit, depending on local preference and codes. Four leadwires are provided on normally open vertical units (that close on temperature rise), per UL requirement, to facilitate supervision of system wiring. Instruments are Underwriters Laboratory and Underwriters Laboratory of Canada listed and Factory Mutual approved for hazardous locations, when mounted in a suitable fitting.

DETECT-A-FIRE in Function:

The secret of the unit's sensitivity is in the design (Figure 1). The outer shell is made of a rapidly expanding alloy which closely follows changes in surrounding air temperature. The inner struts are made of a lower expanding alloy. Designed to resist thermal energy absorption and sealed inside the shell, the struts follow temperature changes more slowly.

A slow rate fire (Figure 2) will heat the shell and struts together. At the "set point," the unit will trigger, actuating the alarm or releasing the extinguishant.

A transient rush of warm air up to 40° F/min. may expand the shell, but not enough to trigger the unit. By ignoring transient warm air excursions, the DETECT-A-FIRE unit virtually eliminates false alarms prevalent with rate-of-rise devices.

If a fast rate fire (Figure 3) starts, the shell will expand rapidly. The struts will close, actuating the alarm or releasing the agent. The faster the fire rate of growth, the sooner the DETECT-A-FIRE unit will react.

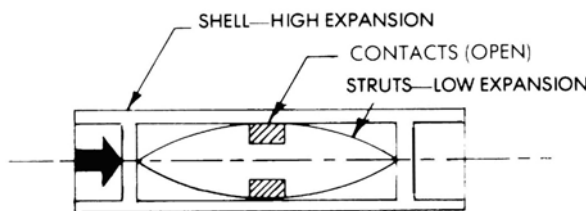

FIGURE 1: READY

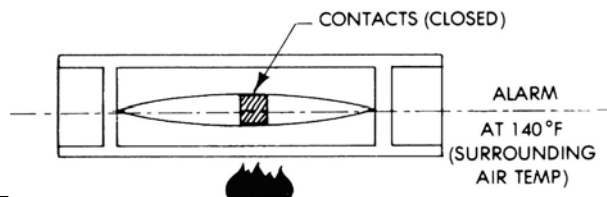

FIGURE 2: SLOW FIRE

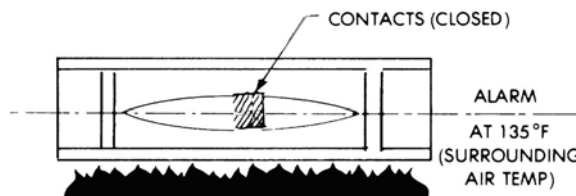

FIGURE 3: FAST FIRE

Agency Listings

Fenwal DETECT-A-FIRE units are UL and ULC listed and FM approved as fire detection thermostats (close on temperature rise) and as releasing devices (open on temperature rise).

AGENCY	FILE NUMBER	LOCATION
UL	S492	Ordinary
UL	E19310	Hazardous
ULC	CS341-E	Ordinary and Hazardous
FM	J.I. OV3HO.AE	Hazardous
FM	17302	Ordinary
UL	S2410	Ordinary (600 & 725 ° F)
UL	E89599	Hazardous (600 & 725 ° F)

Rate of Rise

TYPE OF DEVICE	UNDER 10 ° F/MIN.	BETWEEN 10-40 ° F/MIN	OVER 40 ° F/MIN
Rate Compensated DETECT-A-FIRE Unit	FIRST	FIRST	SECOND but at selected protection level
Fixed Temperature	SECOND	SECOND	THIRD
Rate-of-Rise	Will not operate unless fixed temperature supplement at 165 ° F is provided, then it is THIRD in sequence	Will not operate unless fixed temperature supplement at 165 ° F is provided, then it is THIRD in sequence	FIRST but may be a false alarm

Modifications

12-99202X-XXX, Extended lead wires, Series 12-X271XX and Series 12-X28XXX only. 12-992012-XXX, Fluorocarbon coating, Available on 27120-022, 27121-020, 28020-003, 28021-005 models only (500 ° F max.).

Applications



Typical ceiling installation of a horizontal DETECT-A-FIRE model. Here it is used in combination with a sprinkler system to detect overheat and actuate an alarm.

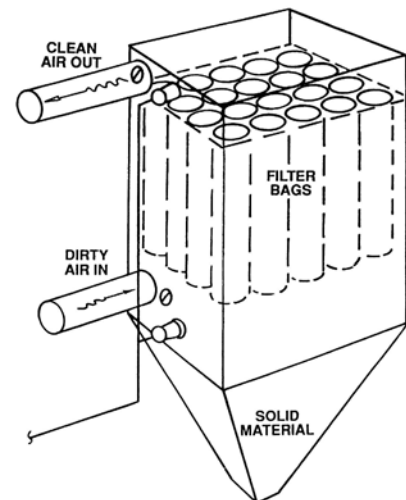

Dust Cover Application

This is a typical application of DETECT-A-FIRE units used as a release device to actuate a complete fire suppression system. In this application DETECT-A-FIRE units are mounted in a Dust Collector to sense an overheat condition and release a clean agent extinguishant.

Construction:

Stainless steel shell sensing element. Cold rolled steel mounting facility. Off-White finish.

Mounting: DETECT-A-FIRE units are not position sensitive. Horizontal and vertical detectors refer to the most common mounting configuration for that unit. However, each type can be mounted either horizontally or vertically depending on the application and installation requirements.

Temperature rating:

Suggested setting a minimum of 100F° above ambient

NOTE: Only units with stainless steel shell and head are approved for Class I, Group A locations.

NOTE A: Spacings shown are distances between units on smooth ceilings, the distances from partitions or walls would be half that shown. Authority having LOCAL jurisdiction should be consulted before installation.

NOTE B: Temperature preset at factory only. Special settings available upon request. Consult LICO for additional information.

NOTE C: In applications where corrosion is suspect, care should be taken to protect the DETECT-A-FIRE unit to realize optimum performance and maximum life. Consult factory for suggestions.

NOTE D: Up to 375° F-#18 AWG Teflon insulated wire used on units. Above 375° F-#16 AWG TGGT insulated wire used on units.

NOTE E: Specifications subject to change without notice.

UL of Canada labeling available upon request.

Although incandescent lamps are considered resistive, their inrush current is 10-15 times their steady current. Do not exceed ratings.

Notes:

- What cannot be installed:
 - Damaged, painted, overheated, overtorqued (more than 27 Newton), fallen (especially on floor) or any other treated, modified or damaged units.
 - Any of this could change the factory setting or even damage the unit now or later, which may result in accidents, injury, loss, damage and even death.
- Never remove any paint, dirt, building debris or other things from the unit: exchange it!
- The above also voids any and any kind of warranty.
- Damaged or shifted units do not necessarily show the evidence outside, therefore:
- Installations at least have to be tested periodically.
- Periodic calibrations are recommended to confirm designed function.
- This information does not describe all details or variations on the equipment described, nor it provides solutions for all possible circumstances. Installation, use and maintenance have to be performed under sufficient failure exclusion considerations according to rules, laws, regulations or necessities of the planned function.

Ordinary Locations: The DETECT-A-FIRE Units are to be installed in grounded metallic junction boxes only. They are to be secured to the boxes using two lock nuts, one on either side of the mounting plate or into an NPT thread. DETECT-A-FIRE Units are not to be installed in non-metallic junction boxes.

Hazardous Locations: For Class I, Division 1 and 2 locations install the DETECT-A-FIRE Unit in a listed explosion-proof enclosure with a minimum thread engagement of five full turns. No non-conductive material is to be placed on the threaded joint of the DETECT-A-FIRE Unit or in the listed explosion-proof enclosure.

For Division 2 locations assure that a protective ground terminal is provided in the listed explosion-proof enclosure when flexible metal conduit is used.

Non-Hazardous Outdoor Locations: Mount the DETECT-A-FIRE in a Listed NEMA Type 3 outlet box, cover and conduit, with 1/2 - 14 NPT threads and a minimum thread engagement of 5 full turns. Use of pipe plugs with RTV silicone rubber sealant, a rubber gasket and self-sealing screws to attach the cover, and PTFE thread seal tape on the DETECT-A FIRE threads should be appropriate for outdoor applications and in accordance with the National Electric Code and/or local authority have jurisdiction.

Field Wiring Requirement: Field wiring must be capable of withstanding the maximum anticipated ambient temperature in the application.

Location:

1. DETECT-A-FIRE detectors are precision temperature sensors. They must be mounted in an area (normally a ceiling) so that: 1.The detector spacing complies with both system requirements and requirements of the agency having local jurisdiction.
2. The thermal air path to the shell is not obstructed. Spacing are usually 8-16 m Distances given are for between units on smooth ceilings. Distances from partitions or walls are half that shown. To assure that all spacing requirements are met, consult the authority having local jurisdiction.

Copyright Fenwal, patents apply. The literature is provided for informational purposes only. LICO assumes no responsibility for the products suitability for a particular application. The product must be properly applied to perform as described herein. If you need more information on this product, or if you have a question, please contact Lico